

# MAV / MAU

# Compactor / Multi Purpose Compactor

With the MAV high frequency Compactor, malleable, loose and semi-solid soil or gravel can be compressed and solidified conveniently and economically using an excavator – to the best advantage, in combination with a Tiltrotator. The same goes for the MAU Multi Purpose Compactor. This together with a MVP compactor plate – which can be easily exchanged with other attachments such as the asphalt cutter ASF M. Also buckets or demolition & sorting grabs can be exchanged via the quick change system for vibrating operations. For excavators from 1t / 2200 lbs to 24t / 52800 lbs operating weight (MAV: up to 45t / 99000 lbs).

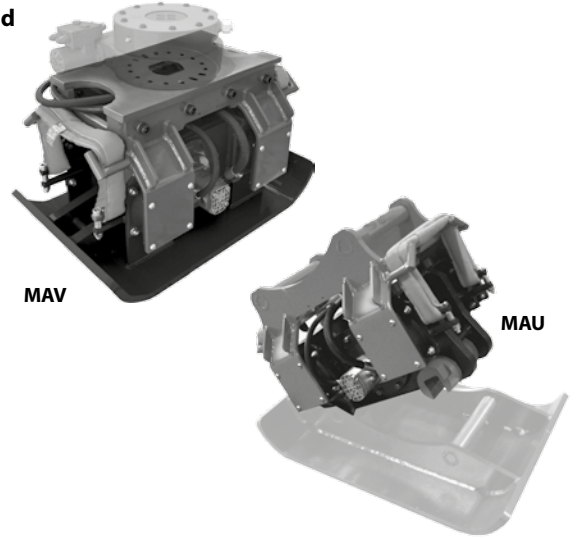

- **Efficiency:** time saving compared to conventional manual compactors. Better for difficult to access or working sites. High compression depth.
- **Safety:** less risk of moving (no swinging) and compacting (no tilting) on malleable soils.
- **Multi purpose:** more than vertical compacting possible. With the MAU, totally new applications are possible through any kind of attachment, and easily exchanged.
- **Longevity:** wear parts made of special steel.

### MAV Compactor

| Type   | Length A (mm/in) | Width B (mm/in) | Height C (mm/in) | Weight (kg/lbs) | Frequency (Hz) | Compactor force (kg/lbs) | Operating weight (t/lbs) |
|--------|------------------|-----------------|------------------|-----------------|----------------|--------------------------|--------------------------|
| MAV 08 | 650 / 25.59      | 400 / 15.75     | 430 / 16.93      | 180 / 396       | 75             | 3500 / 77000             | 1 - 8 / 2200 - 17600     |
| MAV 18 | 900 / 35.43      | 600 / 23.62     | 560 / 22.05      | 380 / 836       | 60             | 7500 / 16500             | 9 - 18 / 19800 - 39600   |
| MAV 35 | 1000 / 39.37     | 740 / 29.13     | 560 / 22.05      | 510 / 1122      | 58             | 7500 / 16500             | 19 - 35 / 41800 - 77000  |
| MAV 40 | 1100 / 43.31     | 850 / 33.46     | 560 / 22.05      | 650 / 1430      | 58             | 14000 / 30800            | 25 - 40 / 55000 - 88000  |
| MAV 45 | 1100 / 43.31     | 850 / 33.46     | 700 / 27.56      | 750 / 1650      | 58             | 14000 / 30800            | 41 - 45 / 90200 - 99000  |

Package consists of: compactor, frame, hydraulic set

### MAU Multi Purpose Compactor

| Type   | Quick hitch | Length A (mm/in) | Width B (mm/in) | Height C (mm/in) | Weight (kg/lbs) | Frequency (Hz) | Compactor force (kg/lbs) | Operating weight (t/lbs) |
|--------|-------------|------------------|-----------------|------------------|-----------------|----------------|--------------------------|--------------------------|
| MAU 06 | S40         | 550 / 51.62      | 400 / 15.75     | 430 / 16.93      | 180 / 396       | 75             | 3500 / 77000             | 1 - 6 / 2200 - 13200     |
| MAU 08 | S45 / S50   | 710 / 27.95      | 600 / 23.62     | 560 / 22.05      | 220 / 484       | 60             | 3500 / 77000             | 5 - 8 / 11000 - 17600    |
| MAU 14 | S45 / S50   | 760 / 29.92      | 740 / 29.13     | 560 / 22.05      | 380 / 836       | 60             | 7500 / 16500             | 9 - 14 / 19800 - 30800   |
| MAU 18 | S60         | 885 / 34.84      | 850 / 33.46     | 560 / 22.05      | 510 / 1122      | 60             | 7500 / 16500             | 12 - 18 / 26400 - 39600  |
| MAU 24 | S70         | 885 / 34.84      | 850 / 33.46     | 560 / 22.05      | 650 / 1430      | 58             | 7500 / 16500             | 19 - 24 / 41800 - 52800  |

### Accessories MAU

| Type                       | Length A (mm/in) | Width B (mm/in) | Weight (kg/lbs) | Cutting wheel (mm/in)   | Quick hitch     | Operating weight (t/lbs) |
|----------------------------|------------------|-----------------|-----------------|-------------------------|-----------------|--------------------------|
| MVP 06 compactor plate     | 650 / 25.59      | 400 / 15.75     | 60 / 132        |                         | S40             | 1 - 6 / 2200 - 13200     |
| MVP 08 compactor plate     | 900 / 35.43      | 600 / 23.62     | 120 / 264       |                         | S45 / S50       | 5 - 8 / 11000 - 17600    |
| MVP 14 compactor plate     | 1000 / 39.37     | 600 / 23.62     | 140 / 308       |                         | S45 / S50       | 9 - 14 / 19800 - 30800   |
| MVP 18 compactor plate     | 1100 / 43.31     | 740 / 29.13     | 220 / 484       |                         | S60             | 12 - 18 / 26400 - 39600  |
| MVP 24 compactor plate     | 1100 / 43.31     | 740 / 29.13     | 220 / 484       |                         | S70             | 19 - 24 / 41800 - 52800  |
| ASF M 40-50 asphalt cutter |                  |                 | 110 / 242       | 450 x 10 / 17.72 x 0.39 | S40, S45 or S50 | 13 - 20 / 28600 - 44000  |
| ASF M 60 asphalt cutter    |                  |                 | 110 / 242       | 450 x 10 / 17.72 x 0.39 | S60             | 21 - 24 / 46200 - 52800  |

### Rotations

| Type                     | Upper connection (mm/in) | Torque (Nm/ft.lbs) | Oper. pressure (max. bar/psi) | Internal pressure (bar/psi) | Bending moment max. (Nm/ft.lbs) |
|--------------------------|--------------------------|--------------------|-------------------------------|-----------------------------|---------------------------------|
| KM 15 F273/273 Rotator   | 10 x M16 / Ø 273 / 10.75 | 2000 / 1475        | 320 / 4608                    | 150 / 2160                  | 50000 / 36875                   |
| RD 12 F273/270 Worm Gear | 16 x M16 / Ø 270 / 10.63 | 7500 / 5531        | 350 / 5040                    | 120 / 1728                  | 28000 / 20650                   |

### Requirements of Excavator

Operating pressure: MAV 08/18/35 and MAU 06/08/14/18/24: **min. 11 MPa (110 bar) / 1584 psi** MAV 40/45: **min. 14 MPa (140 bar) / 2016 psi**  
 Pump capacity (min.-max.): MAV 08, MAU 06/08: 25 - 75 l/min / 6.61 - 19.82 GPM  
 MAV 18/35, MAU 14/18/24: 40 - 120 l/min / 10.57 - 31.70 GPM – MAV 40/45: 90 - 130 l/min / 23.78 - 34.35 GPM

### Technical Drawings

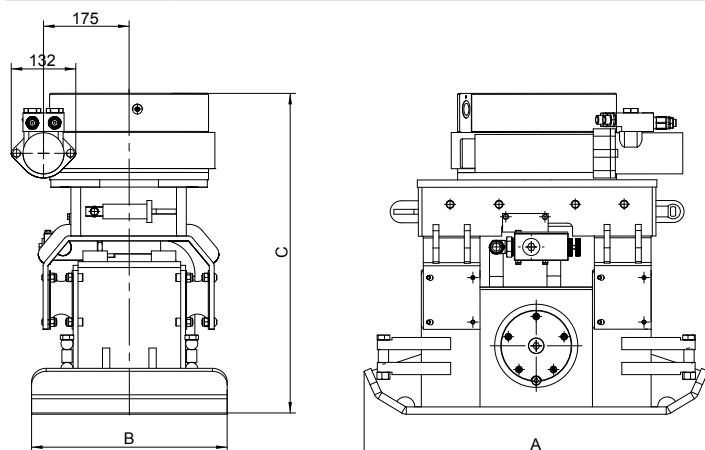

MAV 08 with RD 12 Worm Gear

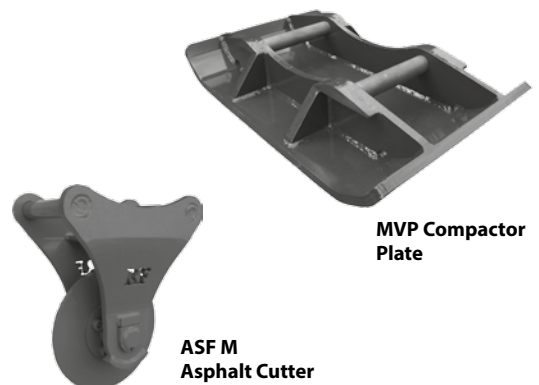

MVP Compactor Plate

ASF M Asphalt Cutter